

# Horizontal Shredding Pumps With Electric Motor

## HPD

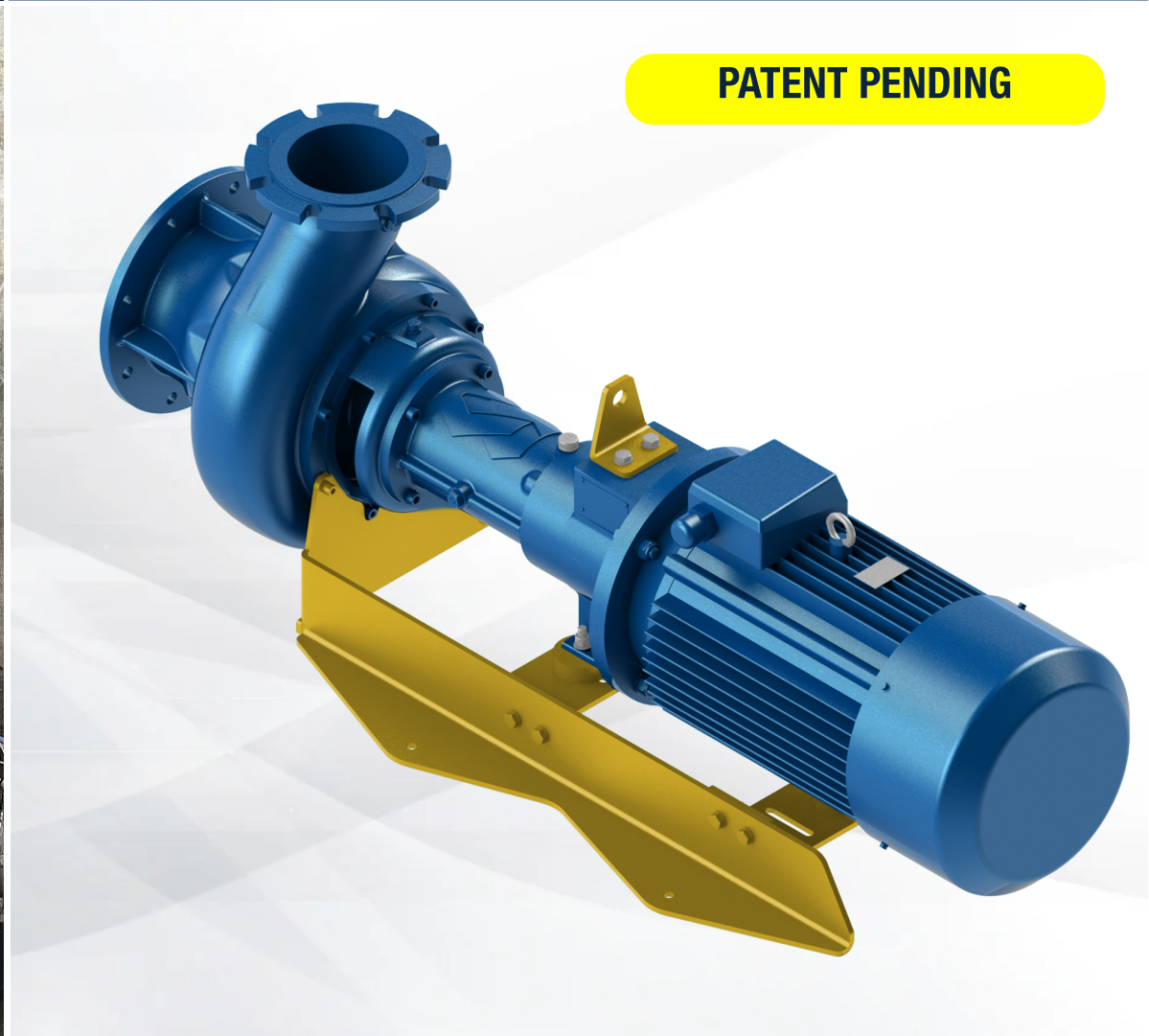

**PATENT PENDING**

## EFFICIENT, SAFE, RELIABLE

CHIOR® HPD is an externally driven horizontal shredding pump designed specifically for the transfer and shredding of biogas digestate, livestock manure and industrial effluents.

At the heart of the innovation is the state-of-the-art cutting system, which guarantees the effective shredding of any material, even the toughest filamentous substances. This means that CHIOR® HPD is always ready to guarantee optimum performance, even under extreme working conditions.

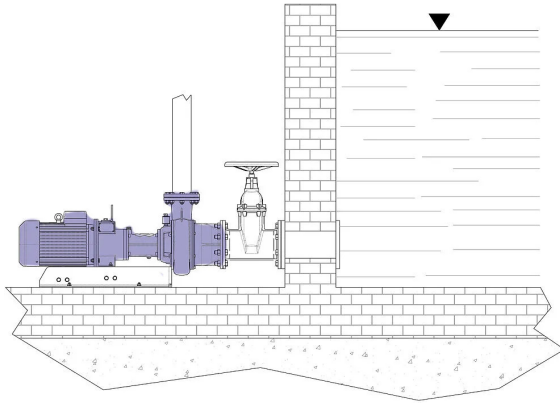

Installation scheme



### Overall Dimensions

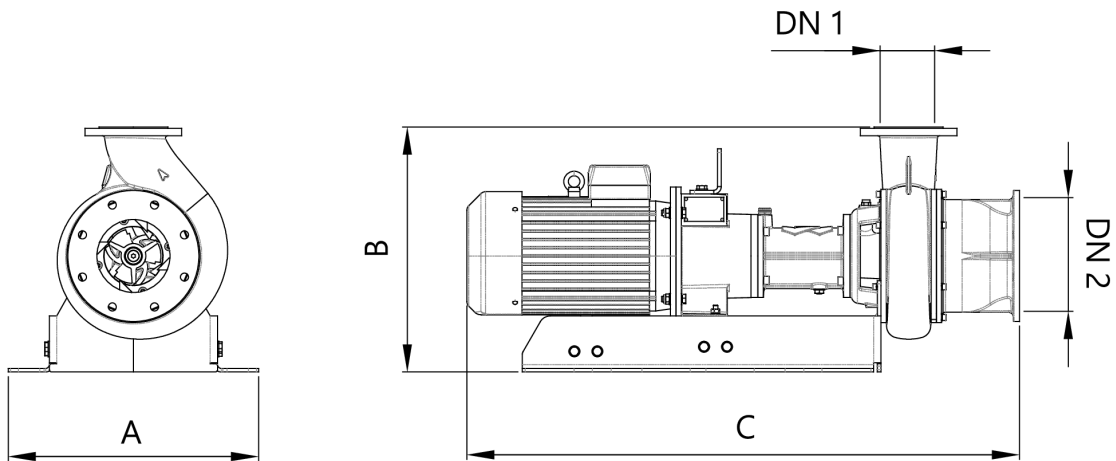

TYPE	Installed Power (kW)	Dimensions A (mm)	Dimensions B (mm)	Dimensions C (mm)	DN 1 (outlet) Flange DN	DN 1 (outlet) Flange PN	DN 2 (suction) Flange DN	DN 2 (suction) Flange PN	Weight (kg)
HPD 055	5.5	545	535	1,145	100	6/10/16	150	10/16	192
HPD 075	7.5			1,185					207
HPD 110	11.0	595	605	1,395	150	200	10	305	
HPD 150	15.0			1,440				325	
HPD 185	18.5			1,465				335	
HPD 220	22.0			1,505				390	

## Benefits

- ✓ **Energy saving:** The high-efficiency electric motor reduces operating costs.
- ✓ **Clogging prevention:** Innovative shredding system ensures uninterrupted operation.
- ✓ **Maximum durability and reliability:** The anti-clogging design reduces maintenance costs and increases reliability.
- ✓ **Self-adjusting cutting system:** Guarantees optimal cutting without need for costly adjustments.
- ✓ **Easy maintenance:** The modular design of the cutting unit simplifies maintenance.
- ✓ **Safety and protection:** The anti-contamination system of the drive unit ensures reliable operation.

## Technical Features

- Innovative chopping system makes multiple cuts per rotation
- Direct contact between the sharp blades and the knives guarantees optimum shredding
- Class IE3 (Premium Efficiency) electric motor
- Three-phase 4-pole motor; IP55 protection class
- Oil-bath lubricated drive unit with bearings
- Elastic coupling between motor and drive shaft
- Knives, impeller and helical conveyor manufactured from treated and hardened materials

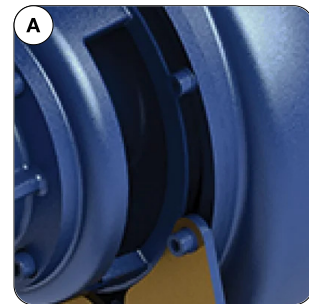

Transmission unit anti-contamination system

HPD 055 - 075

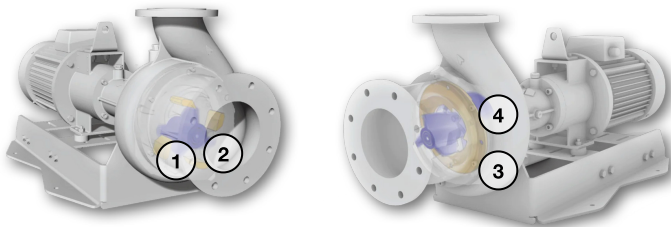

- ① 4 fixed knives
- ② 3-blade helicoid conveyor
- ③ Shredder toothed plate
- ④ Channel impeller with sharp-profile blades

HPD 110 - 150 - 185 - 220

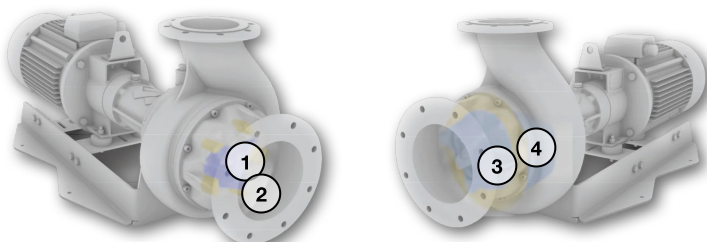

- ① 5 fixed knives
- ② 3-blade helicoid conveyor
- ③ Shredder toothed plate
- ④ Channel impeller with sharp-profile blades

## Range - Performance

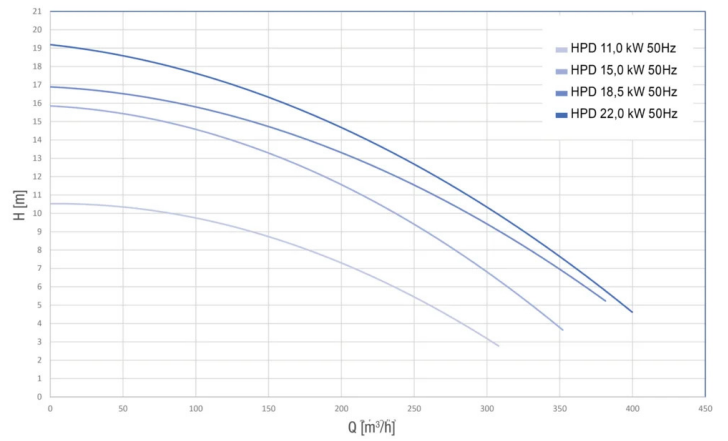
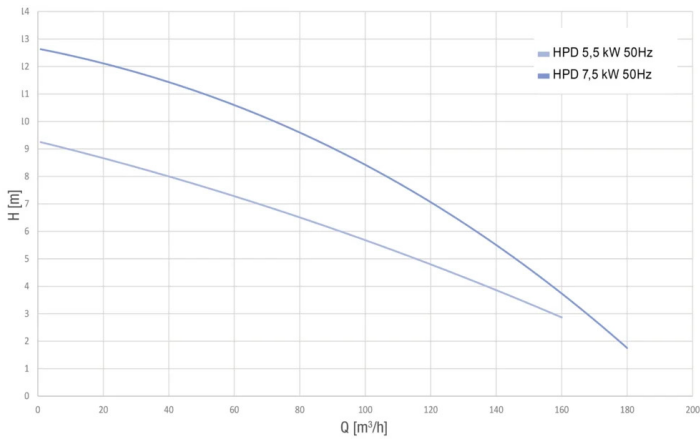

\* Values measured with clear water at 20 °C.

Results may vary by changing the operating conditions depending on the flow rate, density and viscosity of the liquid, the type and dry matter content of the slurry (depending on type of animal feed), the height and distance of the support, as well as the diameter of the pipe.

## Application



August 2025 Rights reserved to modify technical specifications.



This brochure has been edited for distribution in European Union countries.